

HPLC

Author

Roberto Troiano

PerkinElmer
Monza

Rapid Quantitation of Aflatoxins in Corn by HPLC with Kobra Cell Derivatization and Fluorescence Detection

Introduction

Very low level detection of mycotoxins in the agriculture products has become increasingly important. Mycotoxins are very resistant fungal metabolites that can remain in foods after processing and, sometimes, even after cooking. They are considered potent carcinogens and can be found in many varieties of foods. Of the mycotoxin class, aflatoxins are considered especially harmful, being both acutely and chronically toxic. Aflatoxin B1 and B2 are some of the most potent hepatocarcinogens known. Along with aflatoxins G1

and G2, even extremely low levels of these aflatoxins in the diet are important public health concerns. With this in mind, this application describes a specific, robust HPLC method for the low ppb detection of aflatoxins B1, B2, G1 and G2 in corn.

HPLC Configuration

To enhance their natural fluorescence, aflatoxins require derivatization, making them detectable at low ppb levels. The derivatization strategy that is least effected by limitations makes use of the Kobra Cell.¹ This is an electrochemical cell, generating a reactive form of bromine as the derivatizing agent. The derivatization of aflatoxins occurs rapidly at ambient temperatures, in approximately 4 seconds. Also, daily preparation of the derivatizing agent is not required and the derivatization apparatus is quite simple and easy to maintain.

A key component of this approach is the AFLAPREP[®] immunoaffinity sample preparation column (R-Biopharm Rhône, Ltd),² containing a gel suspension of monoclonal antibody covalently attached to a solid support. This antibody is specific for aflatoxins B1, B2, G1 and G2. These aflatoxins are first extracted from homogenized foods using 80:20 methanol/water and diluted 6:1 with phosphate-buffered saline (PBS), pH 7.2. This diluent is then passed through the AFLAPREP[®] column. Any aflatoxins that are present in the diluent are retained by the antibody within the gel suspension. Following, the column is washed with water, removing extraneous non-specific material. The bound toxin is then eluted off the column, using methanol or acetonitrile, and collected in a vial for HPLC analysis.

Recommended HPLC Conditions

Analytical Column:	Validated C18, 100 mm x 4.6 mm, 3 micron
Mobile phase:	Isocratic: 60:10:30 Water/ACN/MeOH, with 119 mg potassium bromide and 350 µL 4 M HNO ₃
Flow:	1.2 mL/min
Temperature:	Ambient
Kobra Cell:	100 uA
Fluorescence Detector:	Excitation: 362 nm; Emission: 435 nm
Injection Volume:	100 u

Suggested HPLC Instrument configuration

Flexar Pump	Binary pump
Flexar VD	Vacuum degasser 3 channels
Flexar Autosampler	Autosampler
Flexar Oven	Column Oven
Flexar FL	Fluorescence detector
Chromera [®]	Chromatography Data System

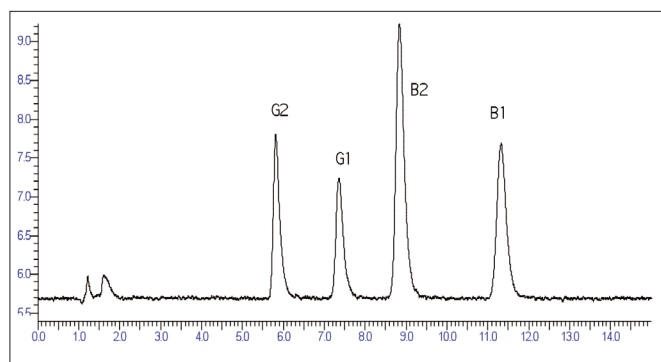
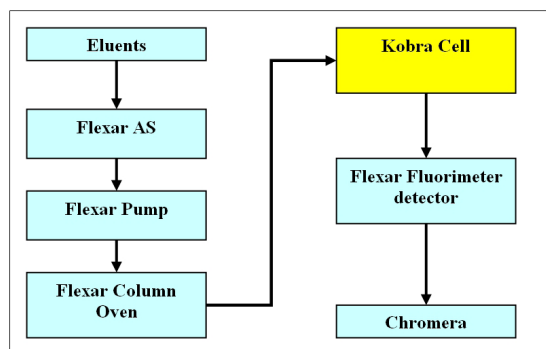

Figure 1. 2 ng/mL (ppb) aflatoxin standard.

PerkinElmer
Via Tiepolo 24
20900 Monza MB
Italia
Tel: 800 906 642
www.perkinelmer.com

Results

As shown in Figure 1, below, the aflatoxins G2, G1, B1 and B2 are all baseline resolved and easily detected at 2 ppb. Considering that the S/N for G1 is about 30, it is expected that an LOD of 0.2 ppb is quite achievable for all four aflatoxins. In Figure 2, the corn sample chromatogram shows that aflatoxins B2 and B1 are both present, with B2 at about 0.3 ppb. Additional results,³ not shown here, indicate that exceptional linearity and reproducibility can also be expected.

Conclusions

The combination of the AFLAPREP[®] immunoaffinity column, HPLC system and Kobra Cell provides several advantages:

- The sample preparation procedure provides robust, reliable aflatoxin extraction with excellent specificity for aflatoxin B1, B2, G1 and G2.
- In combination the Flexar HPLC, the Kobra Cell provides reliable, simple, easily maintained post-column derivatization. This provides a significant time saving, while achieving excellent sensitivity.

References

1. Kobra Cell: <http://www.r-biopharmrhone.com/pro/equip.html>, R-Biopharm Rhône, Ltd.
2. AFLAPREP[®] immunoaffinity column: <http://www.r-biopharmrhone.com/pro/afla/afla1.html>, R-Biopharm Rhône, Ltd.
3. Rapid Quantitation of Aflatoxin B1, B2, G1 and G2 in Corn by HPLC-FLD with Kobra Cell Derivatization without concentration with Immunoaffinity columns (AFLAPREP[®]), Roberto Troriano, PerkinElmer, Inc.

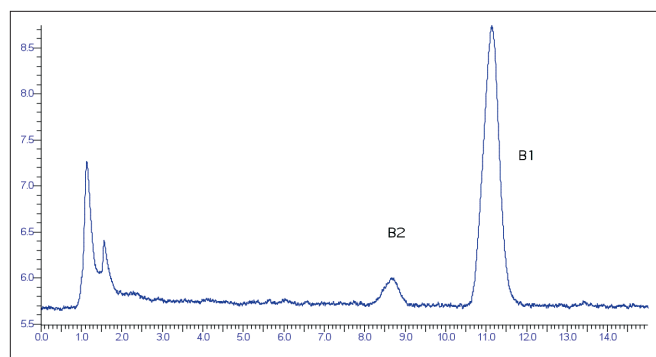

Figure 2. Actual corn sample.

PerkinElmer[®]

Per un elenco completo dei nostri uffici nel mondo visita la pagina www.perkinelmer.com/ContactUs

Copyright ©2011, PerkinElmer, Inc. Diritti riservati. PerkinElmer[®] è un marchio registrato di PerkinElmer, Inc. Tutti gli altri marchi sono di proprietà dei rispettivi detentori.

009583_01